

# Installation Note

---

**Configurable Test Set and Extended Power Range Upgrade Kit  
To Upgrade Option 220 to Option 225**

**Upgrade Kit Order Number: N5230AU-922**

**For N5230A Option 220 PNA-L (20 GHz, 2-Port, Standard Test Set)  
(With serial numbers prefixed MY4640 and above)**



**Agilent Kit Number: N5230-60114**

**Agilent Document Number: N5230-90021**

**Printed in USA March 2007**

Supersedes Print Date: January 2007

© Agilent Technologies, Inc. 2007



N5230-90021

---

## WARRANTY STATEMENT

THE MATERIAL CONTAINED IN THIS DOCUMENT IS PROVIDED “AS IS,” AND IS SUBJECT TO BEING CHANGED, WITHOUT NOTICE, IN FUTURE EDITIONS. FURTHER, TO THE MAXIMUM EXTENT PERMITTED BY APPLICABLE LAW, AGILENT DISCLAIMS ALL WARRANTIES, EITHER EXPRESS OR IMPLIED WITH REGARD TO THIS MANUAL AND ANY INFORMATION CONTAINED HEREIN, INCLUDING BUT NOT LIMITED TO THE IMPLIED WARRANTIES OF MERCHANTABILITY AND FITNESS FOR A PARTICULAR PURPOSE. AGILENT SHALL NOT BE LIABLE FOR ERRORS OR FOR INCIDENTAL OR CONSEQUENTIAL DAMAGES IN CONNECTION WITH THE FURNISHING, USE, OR PERFORMANCE OF THIS DOCUMENT OR ANY INFORMATION CONTAINED HEREIN. SHOULD AGILENT AND THE USER HAVE A SEPARATE WRITTEN AGREEMENT WITH WARRANTY TERMS COVERING THE MATERIAL IN THIS DOCUMENT THAT CONFLICT WITH THESE TERMS, THE WARRANTY TERMS IN THE SEPARATE AGREEMENT WILL CONTROL.

---

## DFARS/Restricted Rights Notice

If software is for use in the performance of a U.S. Government prime contract or subcontract, Software is delivered and licensed as “Commercial computer software” as defined in DFAR 252.227-7014 (June 1995), or as a “commercial item” as defined in FAR 2.101(a) or as “Restricted computer software” as defined in FAR 52.227-19 (June 1987) or any equivalent agency regulation or contract clause. Use, duplication or disclosure of Software is subject to Agilent Technologies’ standard commercial license terms, and non-DOD Departments and Agencies of the U.S. Government will receive no greater than Restricted Rights as defined in FAR 52.227-19(c)(1-2) (June 1987). U.S. Government users will receive no greater than Limited Rights as defined in FAR 52.227-14 (June 1987) or DFAR 252.227-7015 (b)(2) (November 1995), as applicable in any technical data.

---

## Safety Notes

The following safety notes are used throughout this document. Familiarize yourself with each of these notes and its meaning before performing any of the procedures in this document.

---

<b>WARNING</b>	<b>Warning denotes a hazard. It calls attention to a procedure which, if not correctly performed or adhered to, could result in injury or loss of life. Do not proceed beyond a warning note until the indicated conditions are fully understood and met.</b>
----------------	---

---

<b>CAUTION</b>	Caution denotes a hazard. It calls attention to a procedure that, if not correctly performed or adhered to, could result in damage to or destruction of the instrument. Do not proceed beyond a caution sign until the indicated conditions are fully understood and met.
----------------	---

---

---

## Getting Assistance from Agilent

By internet, phone, or fax, get assistance with all your test and measurement needs.

### Contacting Agilent

Assistance with test and measurements needs and information on finding a local Agilent office are available on the Web at:

<http://www.agilent.com/find/assist>

If you do not have access to the Internet, please contact your Agilent field engineer.

---

**NOTE** In any correspondence or telephone conversation, refer to the Agilent product by its model number and full serial number. With this information, the Agilent representative can determine whether your product is still within its warranty period.

---

---

## Description of the Upgrade

This upgrade converts your standard test set analyzer (N5230A Option 220) to a configurable test set extended power range analyzer by adding Option 014, Configurable Test Set and Option 1E1, Source Attenuators. After installation of this upgrade, your analyzer will be an N5230A Option 225.

Option 014, Configurable Test Set adds the additional cabling necessary to allow your analyzer to perform measurements on high power devices and on devices with high dynamic range.

Option 1E1, Source Attenuators adds a 60-dB step attenuator in the signal path of each of the measurement ports. These attenuators are used to adjust the power level (in 10 dB steps) to the device under test (DUT) without changing the power in the reference path.

---

## About Installing the Upgrade

Products affected. . . . .	N5230A Option 220 (20 GHz, 2-port, standard test set) (With serial numbers prefixed MY4640 and above.)
Installation to be performed by . . . . .	Agilent service center or personnel qualified by Agilent
Estimated installation time . . . . .	2.0 hours
Estimated adjustment time . . . . .	0.5 hours
Estimated full instrument calibration time . . . .	4.5 hours

## Items Included in the Upgrade Kit

Check the contents of your kit against the following list. If any part is missing or damaged, contact Agilent Technologies. Refer to [“Getting Assistance from Agilent” on page 3](#).

**Table 1 Contents of Upgrade Kit N5230-60114**

Ref Desig.	Description	Qty	Part Number
	Installation note (this document)	1	N5230-90021
A21, A22	Test port coupler, 26.5 GHz	2	5086-7968
	Rubber bumper (for A21 and A22 test port couplers)	2	0403-0285
A25, A26	0–60 dB step attenuator	2	33325-60012
	Attenuator bracket (for A25 and A26 step attenuators)	2	E8364-00002
	Machine screw, M3 x 8, pan head (to attach attenuator to bracket)	4	0515-0372
	Machine screw, M3 x 6, pan head (to attach bracket to analyzer)	6	0515-0430
	Ribbon cable, A25 step attenuator to A16 test set motherboard P510	1	8121-0819
	Ribbon cable, A26 step attenuator to A16 test set motherboard P512	1	8121-0119
	Cable tie (to secure cables W47 and W51 to the side frame)	4	1400-0249
	Test set deck front panel	1	E8362-00003
	Lower front panel overlay (for configurable test set)	1	N5230-80005
W40	RF cable, A17 MASS 26.5 (A) to A25 port 1 step attenuator	1	N5230-20011
W41	RF cable, A17 MASS 26.5 (B) to A26 port 2 step attenuator	1	N5230-20012
W42	RF cable, A25 port 1 step attenuator to PORT 1 SOURCE OUT	1	E8362-20024
W43	RF cable, A26 port 2 step attenuator to PORT 2 SOURCE OUT	1	E8362-20025
W44	RF cable, PORT 1 CPLR THRU to A21 test port 1 coupler	1	N5230-20045
W45	RF cable, PORT 2 CPLR THRU to A22 test port 2 coupler	1	N5230-20046
W46	RF cable, A17 MASS 26.5 (R1) to REFERENCE 1 SOURCE OUT	1	N5230-20017
W47	RF cable, A17 MASS 26.5 (R2) to REFERENCE 2 SOURCE OUT	1	N5230-20019
W48	RF cable, PORT 1 CPLR ARM to A21 test port 1 coupler	1	E8362-20020
W49	RF cable, PORT 2 CPLR ARM to A22 test port 2 coupler	1	E8362-20021
W50	RF cable, PORT 1 RCVR A IN to A20 mixer brick (A)	1	N5230-20016
W51	RF cable, REFERENCE 1 RCVR R1 IN to A20 mixer brick (R1)	1	N5230-20018
W52	RF cable, REFERENCE 2 RCVR R2 IN to A20 mixer brick (R2)	1	N5230-20020
W53	RF cable, PORT 2 RCVR B IN to A20 mixer brick (B)	1	N5230-20013
W60	Front-panel jumper	6	08720-20098

---

## Installation Procedure for the Upgrade

The network analyzer must be in proper working condition prior to installing this option. Any necessary repairs must be made before proceeding with this installation.

---

**WARNING**      **This installation requires the removal of the analyzer’s protective outer covers. The analyzer must be powered down and disconnected from the mains supply before performing this procedure.**

---

### Electrostatic Discharge Protection

Protection against electrostatic discharge (ESD) is essential while removing or connecting cables or assemblies within the network analyzer.

Static electricity can build up on your body and can easily damage sensitive internal circuit elements when discharged. Static discharges too small to be felt can cause permanent damage. To prevent damage to the instrument:

- *always* have a grounded, conductive table mat in front of your test equipment.
- *always* wear a grounded wrist strap, connected to a grounded conductive table mat, having a 1 M $\Omega$  resistor in series with it, when handling components and assemblies or when making connections.
- *always* wear a heel strap when working in an area with a conductive floor. If you are uncertain about the conductivity of your floor, wear a heel strap.
- *always* ground yourself before you clean, inspect, or make a connection to a static-sensitive device or test port. You can, for example, grasp the grounded outer shell of the test port or cable connector briefly.

Figure 1 shows a typical ESD protection setup using a grounded mat and wrist strap. Refer to “Tools and Equipment Required for the Installation” on page 6 for part numbers.

**Figure 1**    **ESD Protection Setup**

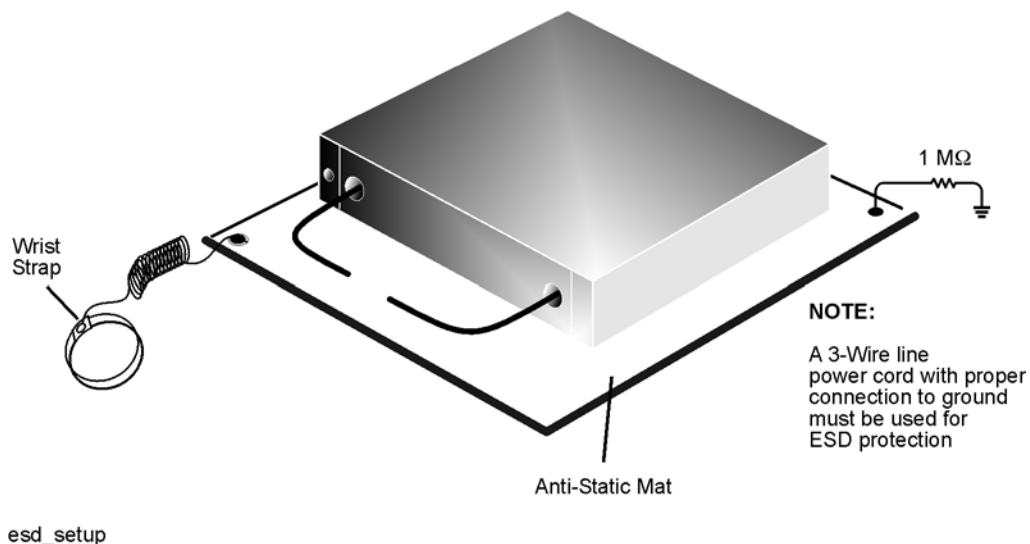

## Tools and Equipment Required for the Installation

Description	Qty	Part Number
T-10 TORX driver (set to 9 in-lbs)	1	N/A
T-20 TORX driver (set to 21 in-lbs)	1	N/A
5/16-in torque wrench (set to 10 in-lbs)	1	N/A
5/16-in torque wrench (set to 21 in-lbs)	1	N/A
1-inch torque wrench (set to 72 in-lbs)	N/A	
ESD grounding wrist strap	1	9300-1367
5-ft grounding cord for wrist strap	1	9300-0980
2 x 4 ft conductive table mat and 15-ft grounding wire	1	9300-0797
ESD heel strap (for use with conductive floors)	1	9300-1308

---

**CAUTION** Use a 5/16-in torque wrench set to 10 in-lbs on all cable connections except the front-panel cable connectors. Use a 5/16-in torque wrench set to 21 in-lbs for these connections.

---

## Equipment Required for Post-Upgrade Adjustments

Equipment Type	Model or Part Number	Alternate Model or Part Number
Power meter	E4418B/E4419B	E4418A/E4419A
Power sensor, 3.5 mm	E4413A	8485A
Adapter, 3.5 mm (f) to 3.5 mm (f)	83059B	85052-60012
RF cable, 3.5 mm (f) to 3.5 mm (f)	85131C	85131E

## Overview of the Installation Procedure

Step 1. Remove the Outer Cover.

Step 2. Remove the Front Panel Assembly.

Step 3. Remove the Existing Cables.

Step 4. Remove the Existing Test Set Deck Front Panel.

Step 5. Install the Front-Panel LED Board and the New Test Port Couplers onto the New Test Set Deck Front Panel.

Step 6. Install the New Test Set Deck Front Panel.

Step 7. Install the Step Attenuators.

Step 8. Install the New Cables.

Step 9. Replace the Lower Front Panel Overlay.

Step 10. Reinstall the Front Panel Assembly and Install the Front Panel Jumpers.

Step 11. Reinstall the Outer Cover.

Step 12. Enable Options 014 and 1E1.

Step 13. Perform Post-Upgrade Adjustments and Calibration.

## Step 1. Remove the Outer Cover

**CAUTION** This procedure is best performed with the analyzer resting on its front handles in the vertical position. *Do not place the analyzer on its front panel without the handles.* This will damage the front panel assemblies.

Refer to [Figure 2](#) for this procedure.

1. Disconnect the power cord (if it has not already been disconnected).
2. With a T-20 TORX driver, remove the strap handles (item ①) by loosening the screws (item ②) on both ends until the handle is free of the analyzer.
3. With a T-20 TORX driver, remove the four rear panel feet (item ③) by removing the center screws (item ④).
4. Slide the four bottom feet (item ⑤) off the cover.
5. Slide the cover off of the frame.

**Figure 2 Outer Cover Removal**

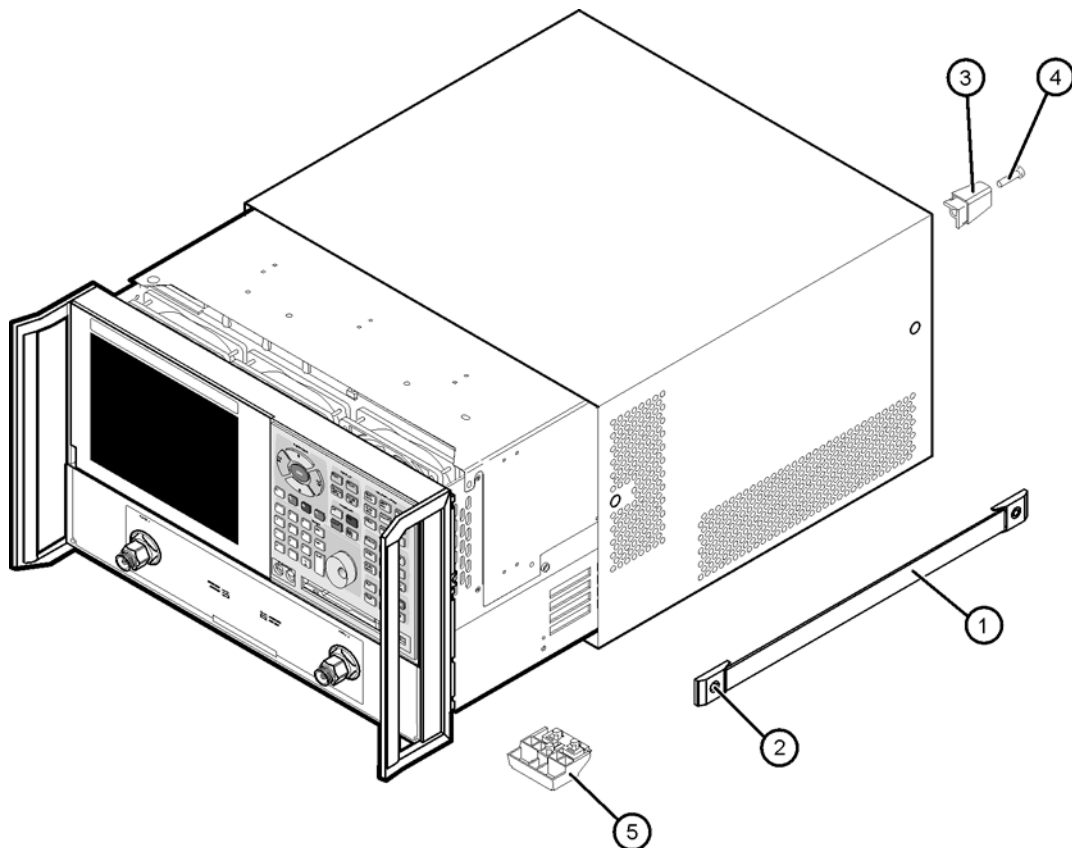

dt501a

## Step 2. Remove the Front Panel Assembly

Refer to [Figure 3](#) for this procedure.

1. With a T-10 TORX driver, remove the eight screws (item ①) from the sides of the frame.

---

**CAUTION** Before removing the front panel from the analyzer, lift and support the front of the analyzer chassis.

---

2. Slide the front panel over the test port connectors.
3. Disconnect the front panel interface ribbon cable (item ②). The front panel is now free from the analyzer.

**Figure 3 Front Panel Assembly Removal**

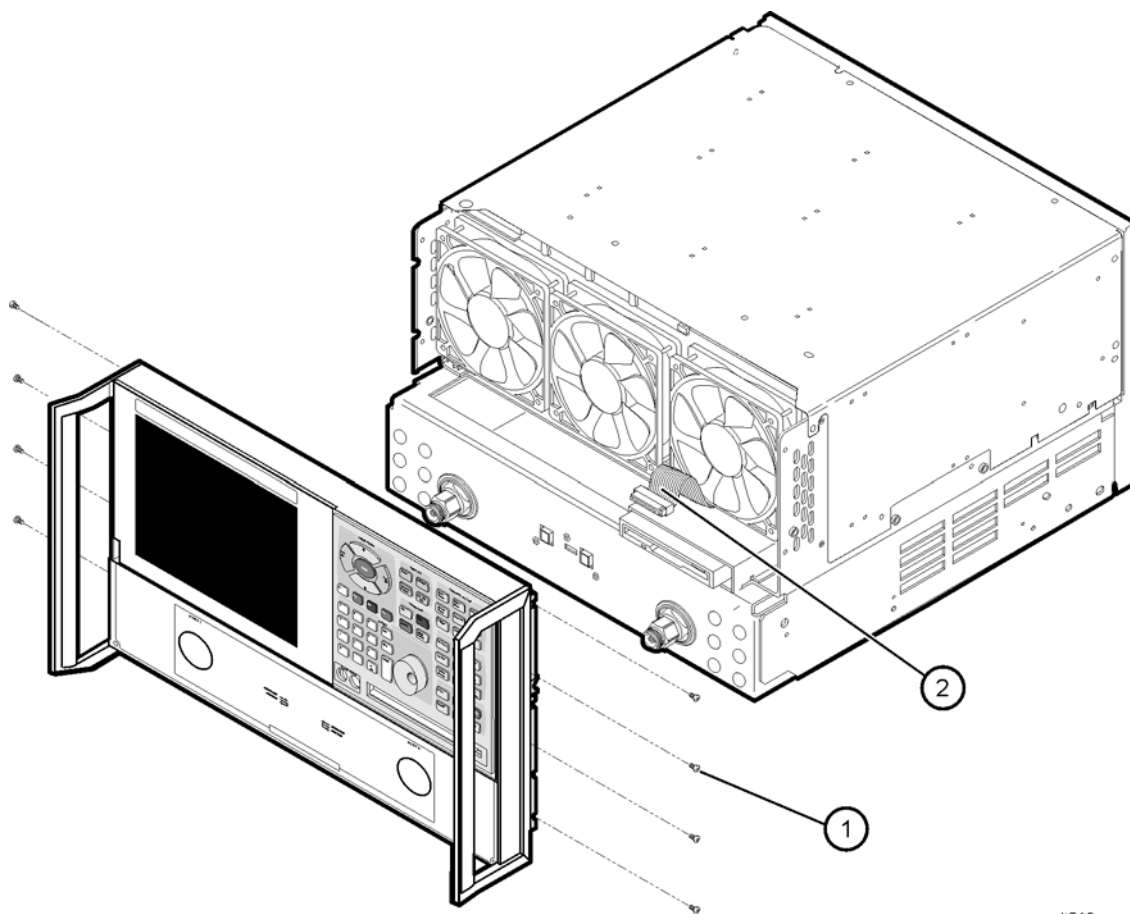

dt513a



### Step 3. Remove the Existing Cables

Refer to [Figure 4](#) for this procedure.

1. Place the analyzer bottom-side up on a flat surface.
2. Remove the following cables in the order listed:
  - W8 A17 MASS 26.5 to A21 test port 1 coupler
  - W10 A17 MASS 26.5 to A20 mixer brick (R1)
  - W12 A21 test port 1 coupler to A20 mixer brick (A)
  - W9 A17 MASS 26.5 to A22 test port 2 coupler
  - W11 A17 MASS 26.5 to A20 mixer brick (R2)
  - W13 A22 test port 2 coupler to A20 mixer brick (B)

**Figure 4 Old Cable Removal**

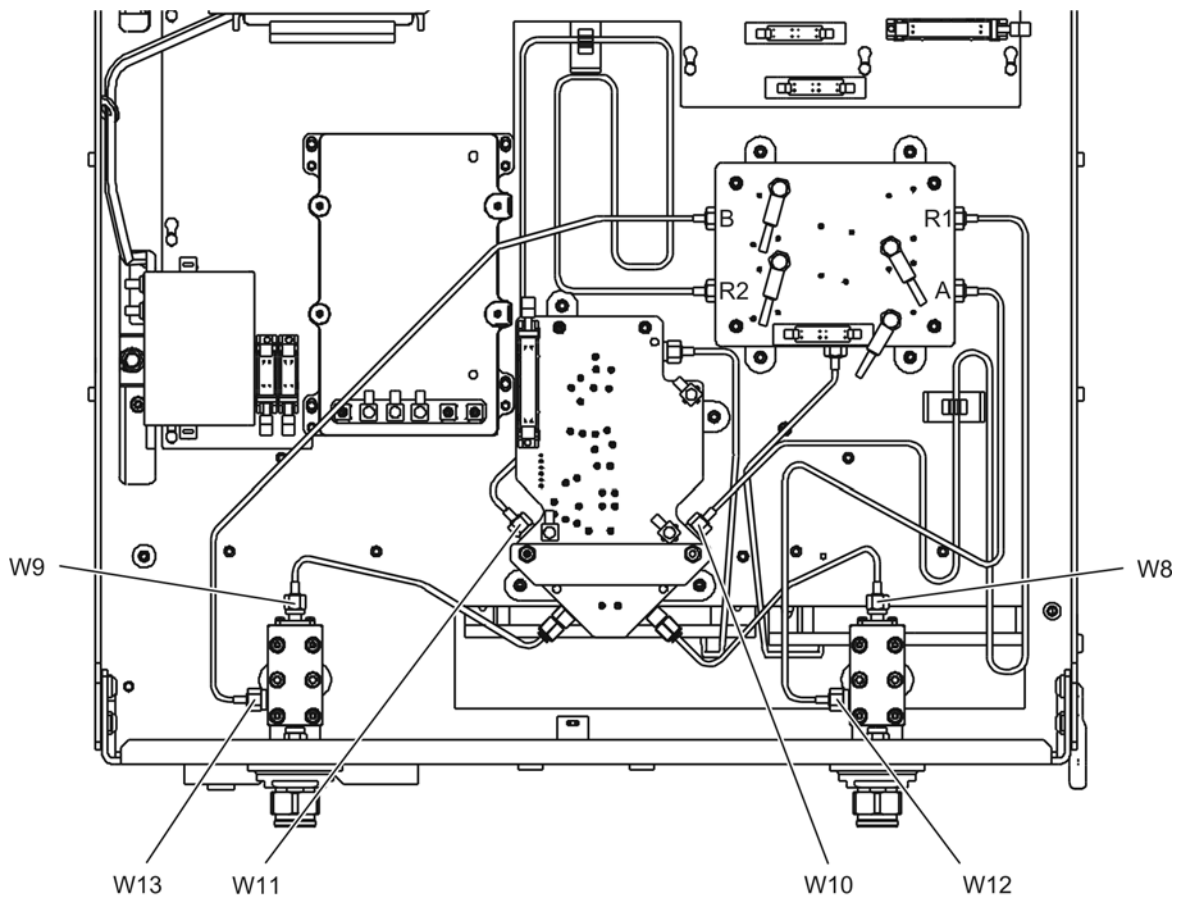

n5230\_021\_01

## Step 4. Remove the Existing Test Set Deck Front Panel

Refer to [Figure 5](#) for this procedure.

1. Disconnect the wrapped wire cable (item ①) from the front-panel LED board.
2. Using a T-10 TORX driver, remove eight screws (items ❶ through ❸) from the test set deck front panel, to release it.
3. Remove the test set deck front panel from the analyzer, with the LED board and both couplers attached.
4. Remove the LED board from the front panel by removing the three attachment screws. Retain the LED board and the screws for installation on the new front panel.
5. Using a 1-inch wrench, remove the flange nut (item ②) from each coupler. Retain the flange nuts for installation of the new couplers. Discard the front panel and the couplers.

**Figure 5 Test Set Deck Front Panel Removal**

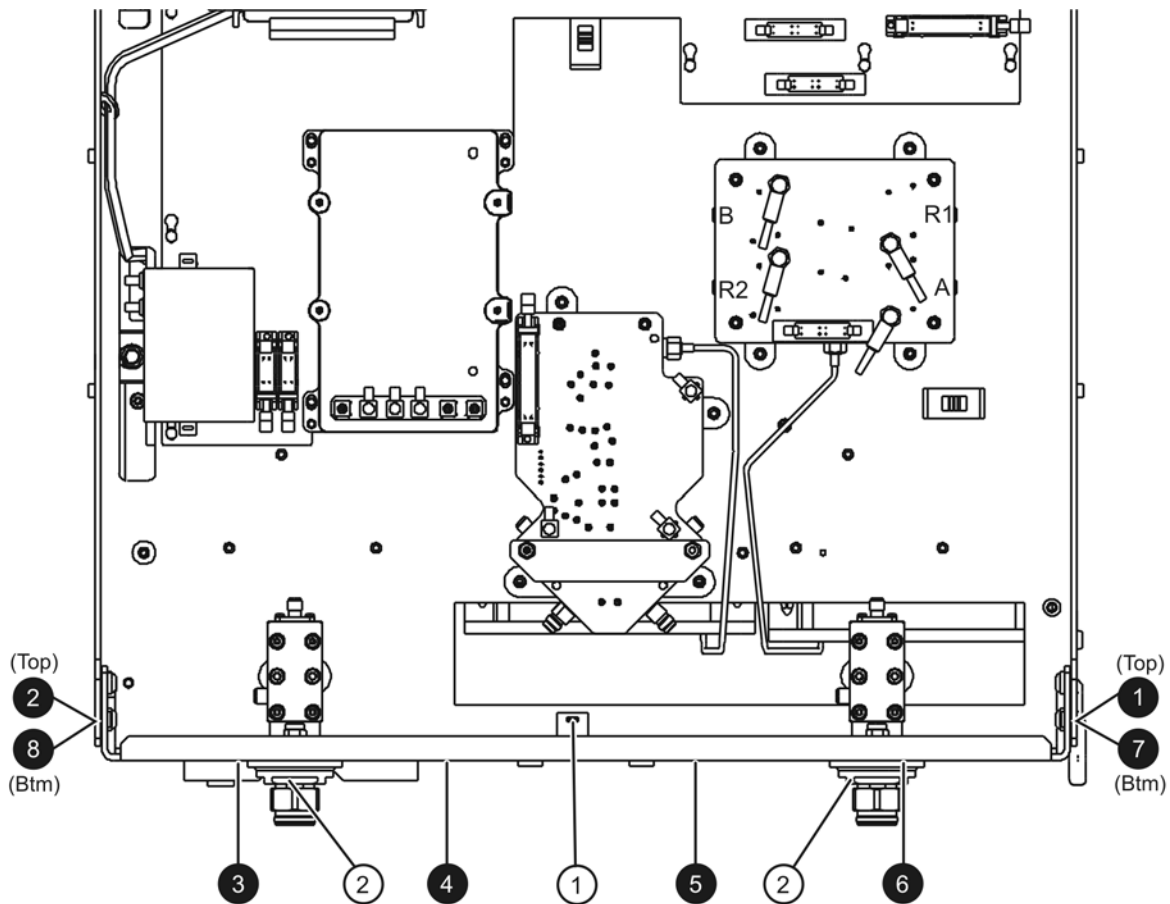

N5230\_010\_15

## Step 5. Install the Front-Panel LED Board and the New Test Port Couplers onto the New Test Set Deck Front Panel

Refer to [Figure 6](#) for this procedure. New parts are listed in [Table 1 on page 4](#).

1. Adhere a rubber bumper to each new coupler as shown below.

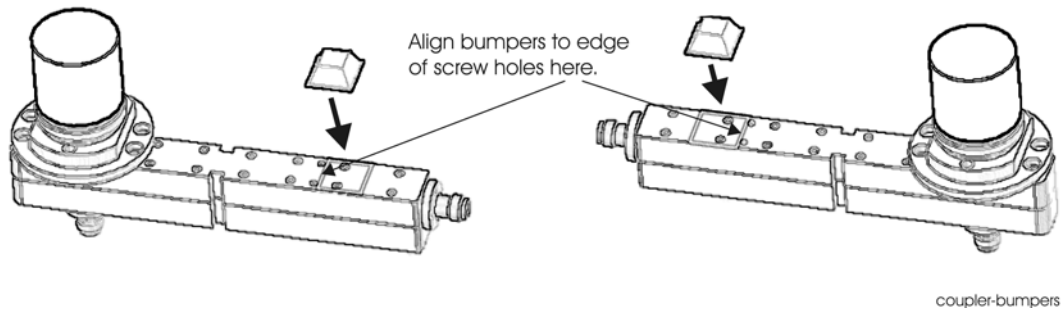

2. Install the LED board removed from the old test set deck front panel onto the new front panel using the three screws (item ①) removed from the old front panel.
3. Install the new couplers in the new test set deck front panel and secure them with the flange nuts (item ②) removed from the old couplers. Torque these flange nuts to 72 in-lbs using a 1-inch torque wrench.

**Figure 6 Front-Panel Components Installation**

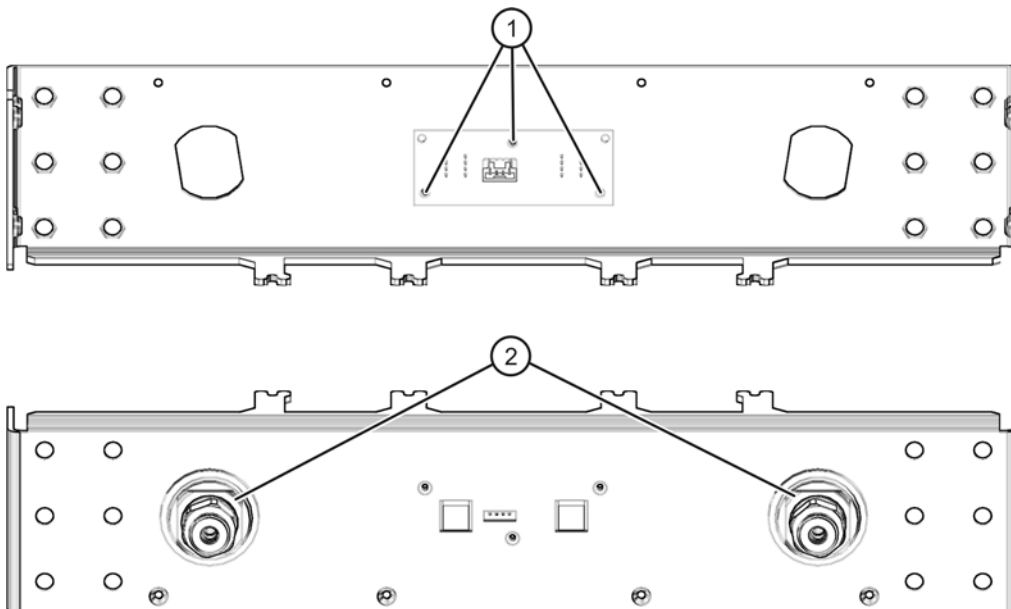

n5230\_021\_04

## Step 6. Install the New Test Set Deck Front Panel

Refer to [Figure 7](#) for this procedure. New parts are listed in [Table 1 on page 4](#).

1. Place the new test set deck front panel, with the LED board and both new couplers attached, onto the test set deck as shown.
2. Using a T-10 TORX driver, *loosely* reinstall the eight screws (items **1** through **8**) to secure the front panel to the test set deck. Once all screws have been loosely installed, torque each of the eight screws to 9 in-lbs in the order indicated (**1** through **8**). This is important to ensure proper alignment.
3. Reconnect the wrapped wire cable (item **1**) to the front-panel LED board.

**Figure 7 Test Set Deck Front Panel Installation**

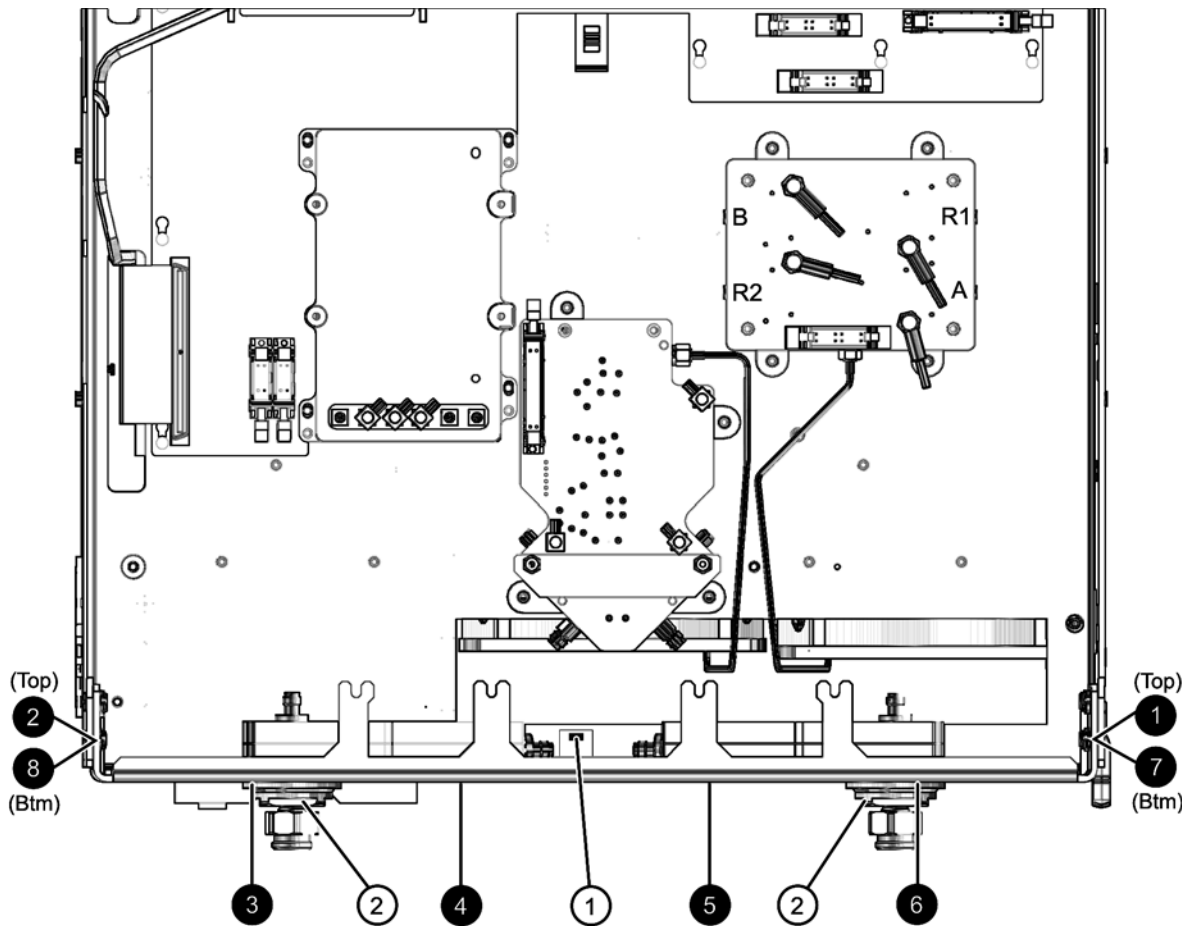

n5230\_010\_04

## Step 7. Install the Step Attenuators

Refer to [Figure 8](#) for this procedure. New parts are listed in [Table 1 on page 4](#).

1. Attach each attenuator (item ①) to an attenuator bracket (item ②) using two screws (item ③) each. Make sure that the attenuators are oriented as shown.
2. Position the attenuators and brackets in the analyzer as shown. Attach the attenuators and brackets onto the analyzer test set deck using three screws (item ④) each.

**Figure 8 Step Attenuator Installation**

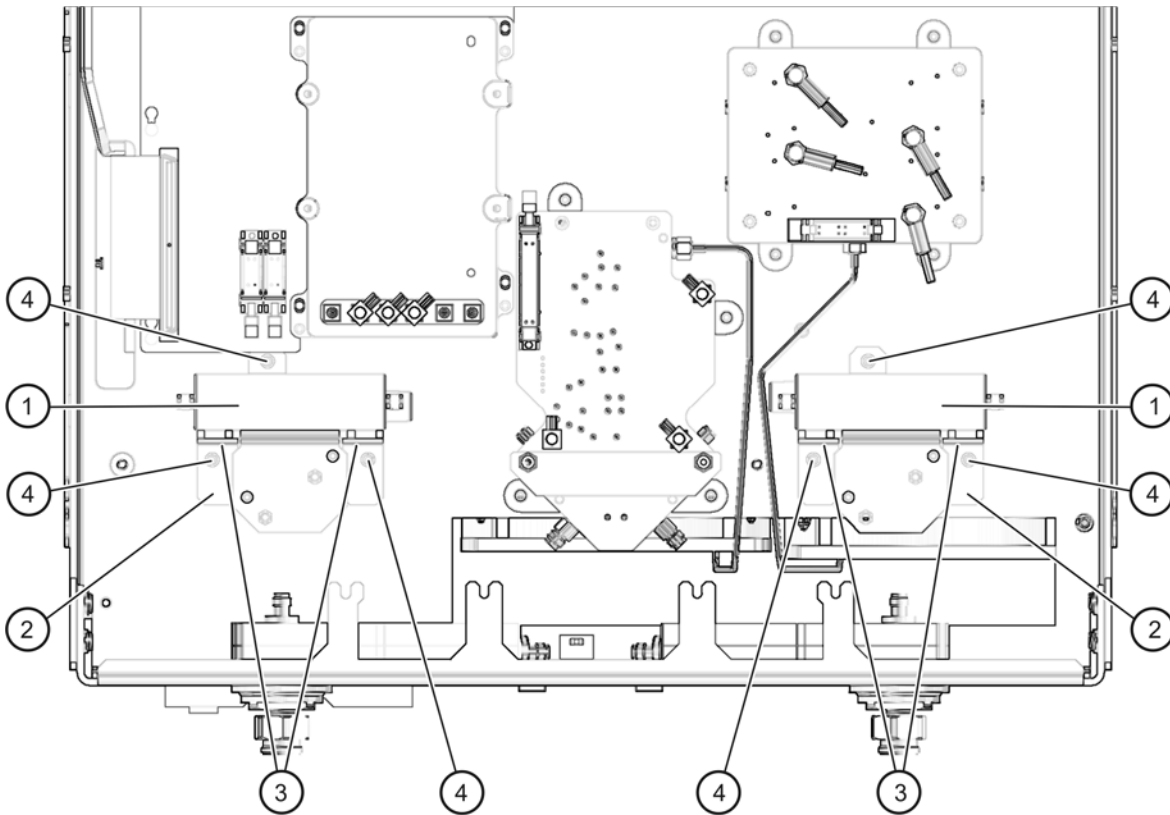

n5230\_005\_02

## Step 8. Install the New Cables

Refer to [Figure 9](#) for the following procedure. New parts are listed in [Table 1 on page 4](#).

1. Install cables W52 and W53:
  - W52 REFERENCE 2 RCVR R2 IN to A20 mixer brick (R2)
  - W53 PORT 2 RCVR B IN to A20 mixer brick (B)
  - a. Loosen the four screws (item ①) that attach the A17 MASS 26.5 to the test set deck.
  - b. Slide cables W52 and W53 between the A17 MASS 26.5 and the test set deck. It will be necessary to move the A17 MASS 26.5 slightly to allow room for the cables.
  - c. Connect cables W52 and W53 as shown. Use a 5/16-in torque wrench set to 10 in-lbs.
  - d. Re-tighten the four screws (item ①) to secure the A17 MASS 26.5.
2. Install the following cables in the order listed. Use a 5/16-in torque wrench set to 10 in-lbs.
  - W49 PORT 2 CPLR ARM to A22 test port 2 coupler
  - W43 A26 port 2 step attenuator to PORT 2 SOURCE OUT
  - W45 PORT 2 CPLR THRU to A22 test port 2 coupler
  - W47 A17 MASS 26.5 to REFERENCE 2 SOURCE OUT
  - W50 PORT 1 RCVR A IN to A20 mixer brick (A)
  - W48 PORT 1 CPLR ARM to A21 test port 1 coupler
  - W44 PORT 1 CPLR THRU to A21 test port 1 coupler
  - W42 A25 port 1 step attenuator to PORT 1 SOURCE OUT
  - W51 REFERENCE 1 RCVR R1 IN to A20 mixer brick (R1)
  - W46 A17 MASS 26.5 to REFERENCE 1 SOURCE OUT
  - W41 A17 MASS 26.5 to A26 port 2 step attenuator
  - W40 A17 MASS 26.5 to A25 port 1 step attenuator
3. Secure cables W47 and W51 to the analyzer side frame using cable ties (item ②) in the locations shown.
4. Using a 5/16-in torque wrench set to 21 in-lbs, tighten the hex nuts (item ③) on all 12 front panel cable connectors.
5. Connect a ribbon cable to each of the step attenuator connectors (item ④):
  - a. The longer cable, 8121-0819, connects between the A25 step attenuator and A16P510 (P1 SRC ATT).
  - b. The shorter cable, 8121-0119, connects between the A26 step attenuator and A16P512 (P2 SRC ATT).

**Figure 9 New Cable Installation**

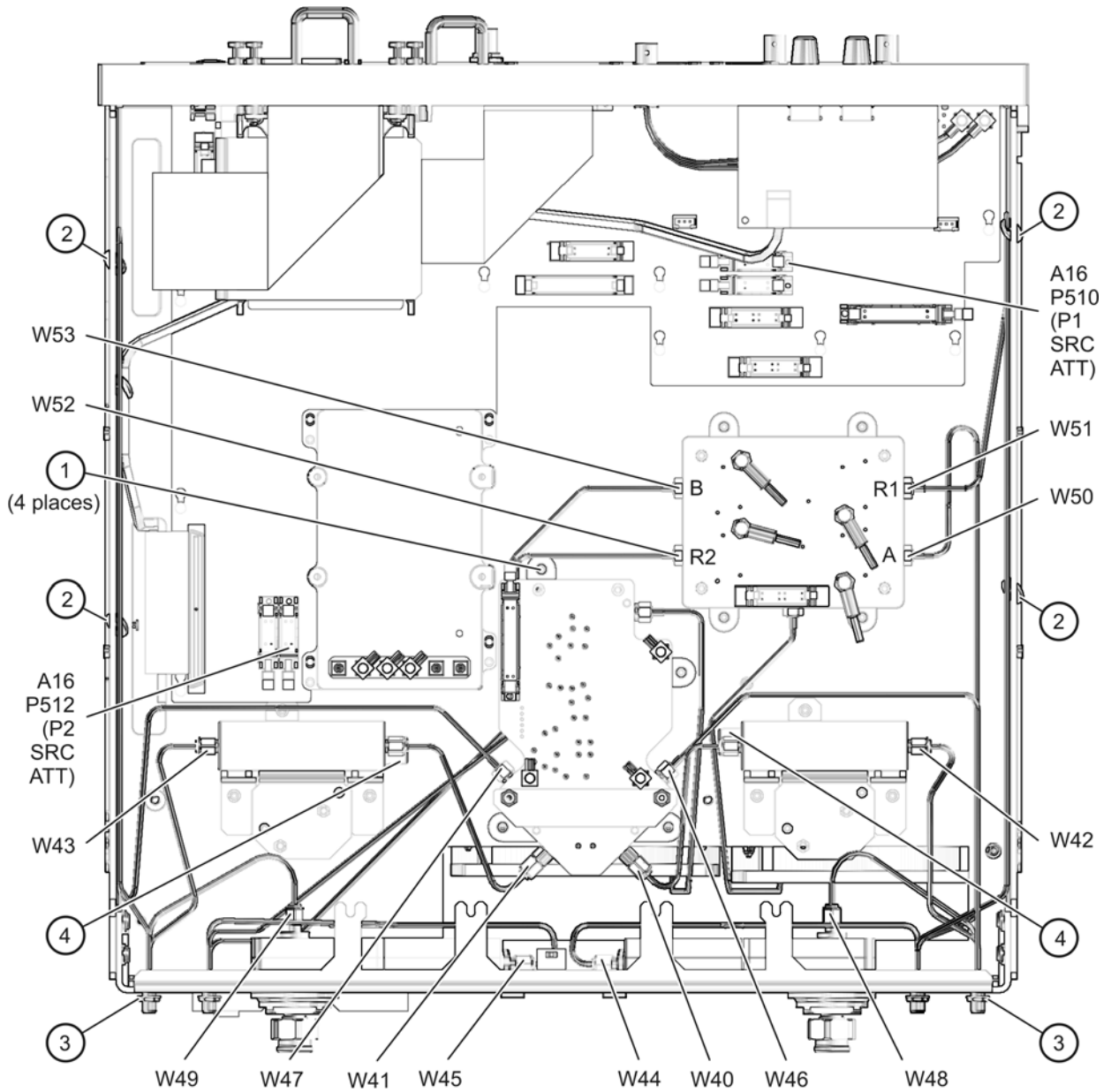

n5230\_005\_03

## Step 9. Replace the Lower Front Panel Overlay

Refer to [Figure 10](#) for this procedure. New parts are listed in [Table 1 on page 4](#).

1. From the back side of the front panel, use a blunt object in one of the cutouts in the lower frame to push the overlay (item ①) and separate it from the front panel.
2. From the front side of the front panel, pull off the overlay completely and discard it.
3. Remove any adhesive remaining on the front panel.
4. Remove the protective backing from the new front panel overlay (item ①).
5. Starting from either the left or right side, *loosely* place the overlay in the recess on the lower front panel, ensuring that it fits tightly against the edges of the recess.
6. Once the overlay is in place, press it firmly onto the frame to secure it.

**Figure 10 Lower Front Panel Overlay Replacement**

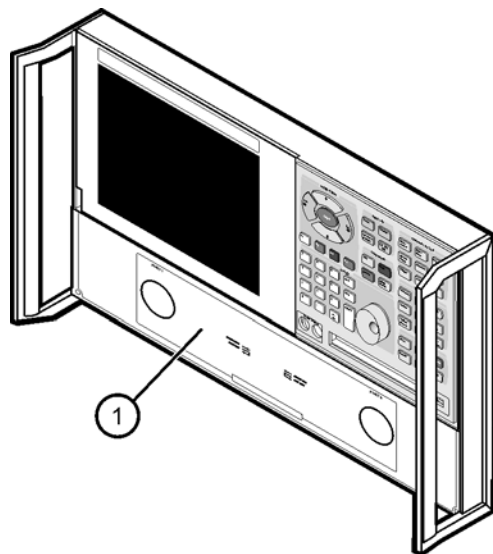

dt519a



## Step 10. Reinstall the Front Panel Assembly and Install the Front Panel Jumpers

**CAUTION** Before installing the front panel assembly onto the analyzer, lift and support the front of the analyzer chassis.

Refer to [Figure 11](#) for this procedure. New parts are listed in [Table 1 on page 4](#).

1. Make sure all 12 of the hex nuts on the front-panel cable connectors have been tightened using a 5/16-in torque wrench set to 21-in lbs.
2. Reconnect the ribbon cable (item ①) to the A3 front panel interface board.
3. Slide the front panel over the test port connectors being careful to align the power switch and floppy disk drive to their corresponding front panel cutouts. Ensure that the ribbon cable (item ①) is located below the fan to prevent it from being damaged by the fan blades.
4. With a T-10 TORX driver, install the eight screws (item ②) in the sides of the frame.
5. Install the six semirigid jumpers (item ③) on the front panel, and tighten to 10-in lbs.

**Figure 11 Front Panel Assembly Reinstallation**

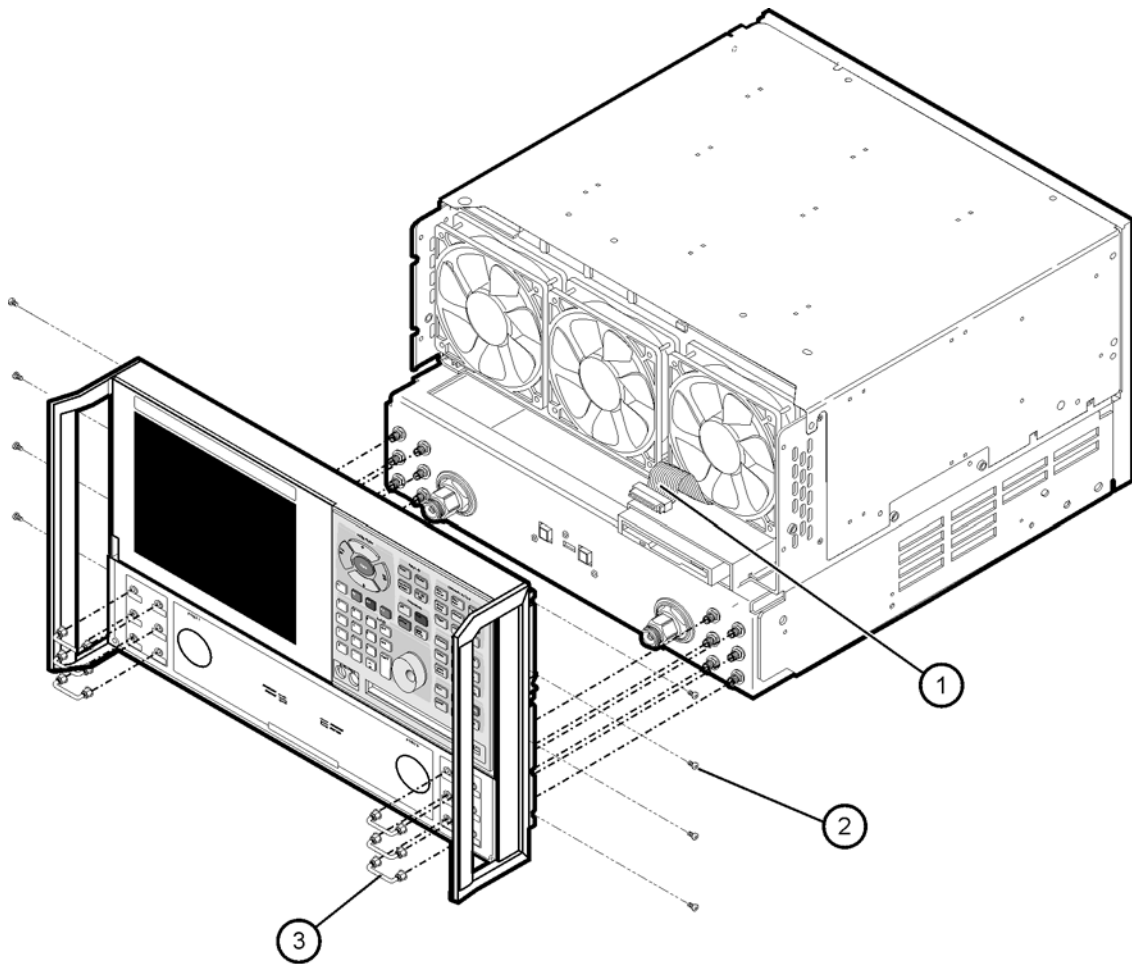

d511a

## Step 11. Reinstall the Outer Cover

**CAUTION** This procedure is best performed with the analyzer resting on its front handles in the vertical position. *Do not place the analyzer on its front panel without the handles.* This will damage the front panel assemblies.

Refer to [Figure 12](#) for this procedure.

1. Slide the cover over the analyzer frame.
2. With a T-20 TORX driver, install the four rear panel feet (item ①) by installing the center screws (item ②).
3. Slide the four bottom feet (item ③) into position on the cover.
4. With a T-20 TORX driver, install the strap handles (item ④) by installing the screws (item ⑤) on both ends of the handles.

**Figure 12 Outer Cover Reinstallation**

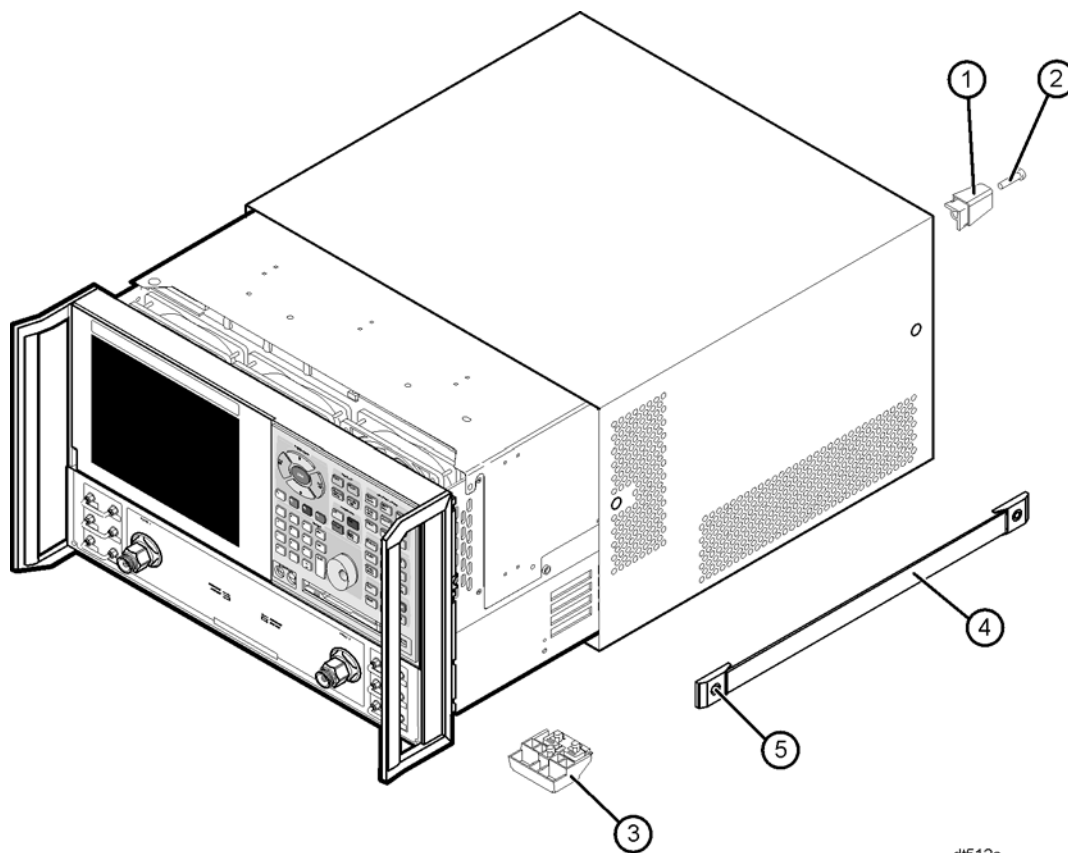

## Step 12. Enable Options 014 and 1E1

### Procedure Requirements

- The analyzer must be powered up and operating to perform this procedure.
- The Network Analyzer program must be running.
- A mouse must be connected to the analyzer for this procedure.

### Option Enable Procedure

1. On the analyzer's **System** menu, point to **Service**, and then click **Option Enable**.
2. In the **Select Desired Option** list, click **014 - Configurable Test Set**. Click **Enable**.
3. In the **Select Desired Option** list, click **1E1 - Source Attenuators**. Click **Enable**.
4. Click **Yes** in answer to the displayed question in the **Restart Analyzer?** box.
5. When the installation is complete, click **Exit**.

### Option Verification Procedure

Once the analyzer has restarted and the Network Analyzer program is again running:

1. On the analyzer's **Help** menu, click **About Network Analyzer**.
2. Verify that "014" and "1E1" are listed after "Options:" in the display. Click **OK**.

---

**NOTE** If Options 014 and 1E1 have not been enabled, perform the "[Option Enable Procedure](#)" again. If the options are still not enabled, contact Agilent Technologies. Refer to "[Getting Assistance from Agilent](#)" on page 3.

---

## Step 13. Perform Post-Upgrade Adjustments and Calibration

### Adjustments

The following adjustments must be made due to the hardware changes of the analyzer.

- source calibration
- receiver calibration

These adjustments are described in the PNA service guide and in the PNA on-line HELP. A list of equipment required to perform these adjustments can be found at [“Equipment Required for Post-Upgrade Adjustments” on page 6](#).

### Calibration

The analyzer should now operate and phase lock over its entire frequency range.

If you experience difficulty with the basic functioning of the analyzer, contact Agilent. Refer to [“Getting Assistance from Agilent” on page 3](#).

- Although the analyzer functions, its performance relative to its specifications has not been verified.
- It is recommended that a full instrument calibration be performed using the N2721A performance test software.
- Refer to the analyzer’s service guide for information on the performance test software.